

Cement Resistors

Standard Type & Non-Inductive Type

SQP SQT SQM SQZ SQH SQF Series

INTRODUCTION

The materials used and the construction techniques ensure excellent flame resistance, are resistance and moisture resistances as self-extinguishing capabilities. They will withstand the most rigorous loading test.

As resistors in radio and television receivers, the hazardous conditions of smoking and redheat can be completely prevented by the proper choice of power resistors.

FEATURES

- Small dimension, excellent stability in high temperature, resistant to humidity and shock with economic price.
- Completely insulated character suitable for printed circuit board.
- Precise resistance value with better life proof.
- In high resistance value, the winding core will be replaced by Metal Oxide Film cutting core (RS).
- Super heat dissipation : small linear temperature coefficient.
- Instant overload capability : low noise figure and without annual shift on resistance value.
- Applicable specifications : EIA RS-344 and EIA RC-649.
- Standard tolerance : $\pm 5\%$.

Series SQP NSP

AXIAL LEAD TYPE

SQP (STANDARD TYPE)

NSP (NON-INDUCTIVE TYPE)

FROM 2W TO 20W

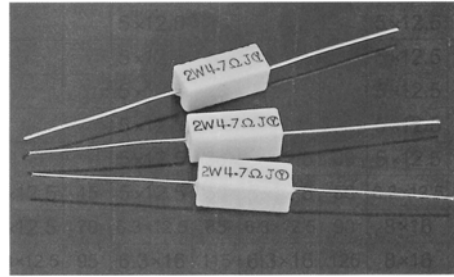

FEATURES

- Exceptionally small and sturdy : mechanically safe. Excellent electrical characteristics.
- The materials used and the construction techniques ensure excellent flame resistance, are resistance and moisture resistance as well as self-extinguishing capabilities. They will withstand the most rigorous loading test.
- As resistors in radio and television receivers, the hazardous conditions of smoking and redheat can be completely prevented by the proper choice of power resistors.
- Tolerances of 5% and 10% are standard.
- Applicable specifications : EIA RS-344 and EIA RC-649.

DERATION CURVE

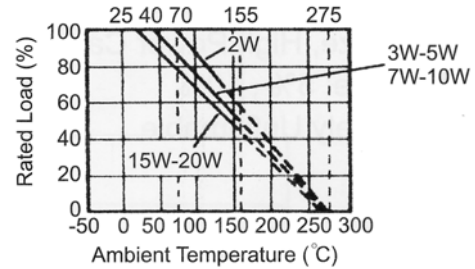

TEMPERATURE RISE

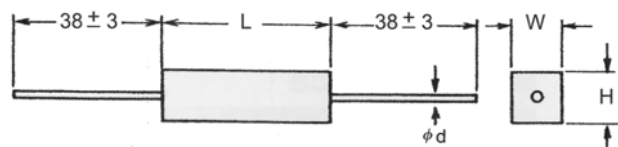
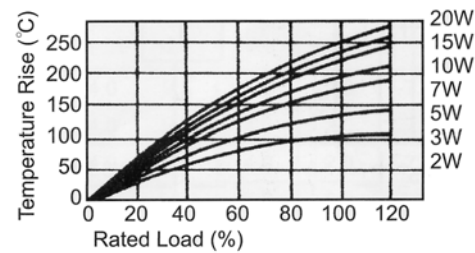

Type	Dimensions (mm)			Range (OHM)	
	L ±0.5	W ±1	S ±1	Inside Core Wire Wound	Inside Core Metal Oxide
2W	18.0	7.0	0.8	0.1-60	61-33K
3W	22.0	8.0	0.8	0.1-180	181-33K
5W	22.0	10.0	0.8	0.1-180	181-50K
7W	35.0	10.0	0.8	0.1-430	431-50K
10W	48.0	10.0	0.8	0.1-470	471-50K
15W	48.0	12.5	0.8	0.5-600	601-150K
20W	60.0	14.5	0.8	0.5-1K	1K1-150K

PERFORMANCE

Temperature Coefficient	± 300 PPM/°C
Insulation Resistance	>100 MΩ
Load Life (1,000 hours)	± 5% + 0.05Ω
Short-Time Overload	± 2% + 0.05Ω
Dielectric Withstanding Volt	± 2% + 0.05 Ω
Moisture Resistance	± 5% + 0.05 Ω
Shock and Vibration	± 1% + 0.05 Ω
Effect of Soldering	± 2% + 0.05 Ω

Note : 1.Non-Inductive type up to 50Ω only.

Series SQM NSM

RADIAL LEAD TYPE

SQM (STANDARD TYPE)

NSM (NON-INDUCTIVE TYPE)

FROM 2W TO 10W

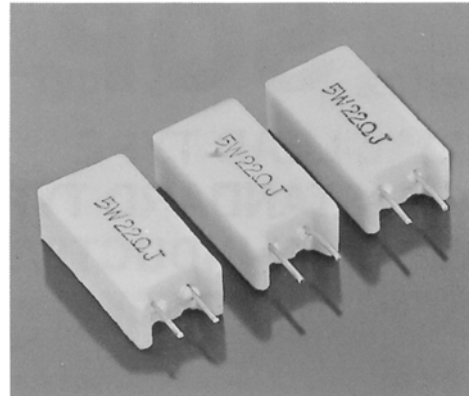

FEATURES

- Space Saving Stand-Off Type
- Small Size, High Power Capacity
- Tolerance : 5%, 10%
- Completely Unflamabel

DERATING CURVE

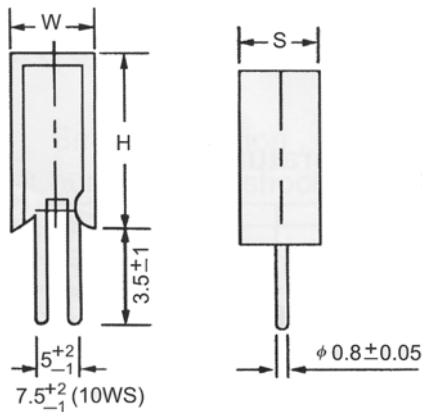
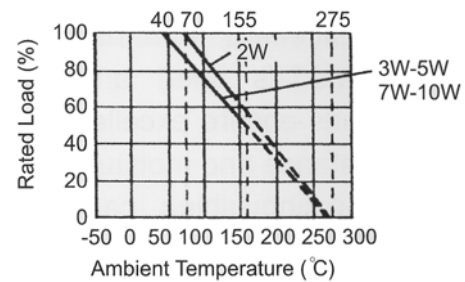

TEMPERATURE RISE

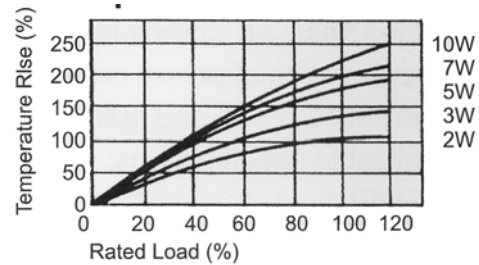

PERFORMANCE

Type	Dimensions (mm)			Range (OHM)	
	H ±1.5	W ±1	S ±1	Inside Core Wire Wound	Inside Core Metal Oxide
2W	20	11	7	0.1-60	61-33K
3W	25	12	8	0.1-180	181-33K
5W	25	13	9	0.1-180	181-50K
7W	39	13	9	0.1-430	431-50K
10WS	35	16	12	0.1-430	431-50K
10W	51	13	9	0.1-470	471-50K

Temperature Coefficient	±300 PPM/°C
Insulation Resistance	>100 MΩ
Load Life (1,000 hours)	± 5% + 0.05Ω
Short-Time Overload	± 2% + 0.05Ω
Dielectric Withstanding Volt	± 2% + 0.05 Ω
Moisture Resistance	± 5% + 0.05 Ω
Shock and Vibration	± 1% + 0.05 Ω
Effect of Soldering	± 2% + 0.05 Ω

Note : 1.Special size on request.
2.Non-Inductive type up to 50Ω only.

Series SQZ NSZ

PCB MOUNTING TYPE

SQZ (STANDARD TYPE)

NSZ (NON-INDUCTIVE TYPE)

FROM 5W TO 20W

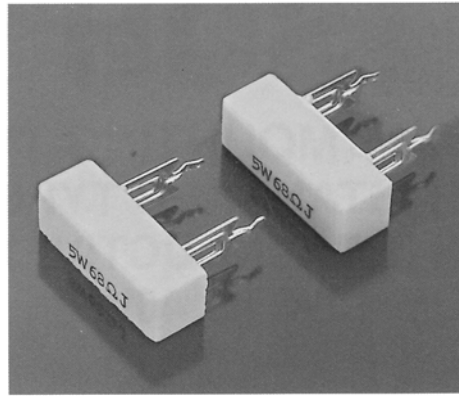

FEATURES

- Space Saving Stand-Off Type
- Non-Inductive Type Up to 50Ω Available
- Tolerance : 5%, 10%
- Completely Unflamabel

DIMENSIONS

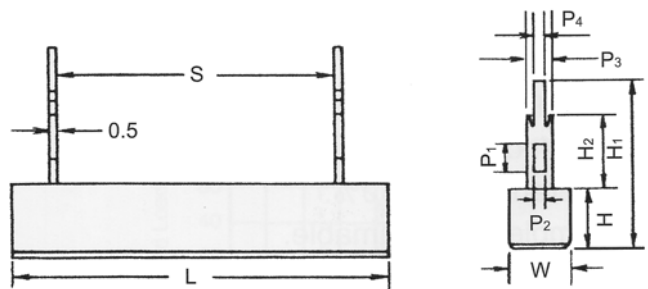

PERFORMANCE

Power Rating (W)	Range of Resistance (Ω)		Dimensions (mm)									
	Inside Core Wire Wound	Inside Core Metal Oxide	L ±1.5	H ±1.5	W ±1.5	S ±1.5	H1 ±1	H2 ±1	P1	P2	P3	P4
5W	0.1-200	201-50K	25(28)	9.5	9.5	9.5(15)	24.0	9.5	4.0	2.0	7.5	1.4
7W	0.1-500	501-50K	35.0	9.5	9.5	20.5	24.0	9.5	4.0	2.0	7.5	1.4
10W	0.1-800	801-50K	48.0	9.5	9.5	32.0	24.0	9.5	4.0	2.0	7.5	1.4
15W	0.1-800	801-150K	48.0	12.5	12.5	32.0	34.5	15.0	7.0	6.0	10.0	2.7
20W	0.5-1K	1K1-150K	63.0	12.5	12.5	45.0	34.5	15.0	7.0	6.0	10.0	2.7

Note : Resistance up to 50Ω maximum for Non-Inductive type

POWER DERATING CURVE

Temperature Coefficient	300 PPM/°C
Insulation Resistance	100MΩ
Load Life (1,000 Hours)	±5% +0.05Ω
Short-Time Overload	±2% +0.05Ω
Dielectric Withstanding Volt	±2% +0.05Ω
Moisture Resistance	±5% +0.05Ω
Shock and Vibration	±1% +0.05Ω
Effect of Soldering	±2% +0.05Ω

POWER DERATING CURVE

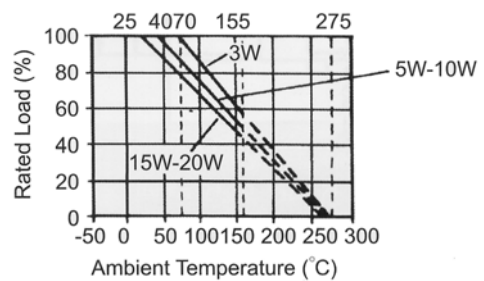

Series SQH NSH

CLAMP MOUNTING TYPE

SQH (STANDARD TYPE)

NSH (NON-INDUCTIVE)

FROM 10W TO 40W

FEATURE

- Low Cost
- Small size High power capacity
- Non-Inductive type up to 50Ω available
- Tolerance : 5%, 10%
- Completely unflamable.

PERFORMANCE

Temperature Coefficient	±300 PPM/°C
Insulation Resistance	>100 MΩ
Load Life (1.000 hours)	±5% +0.05 Ω
Short-time Overload	±2% +0.05 Ω
Dielectric Withstanding Volt	±2% +0.05 Ω
Moisture Resistance	±5% +0.05 Ω
Shock and Vibration	±1% +0.05 Ω
Effect of Soldering	±2% +0.05 Ω

DIMENSIONS

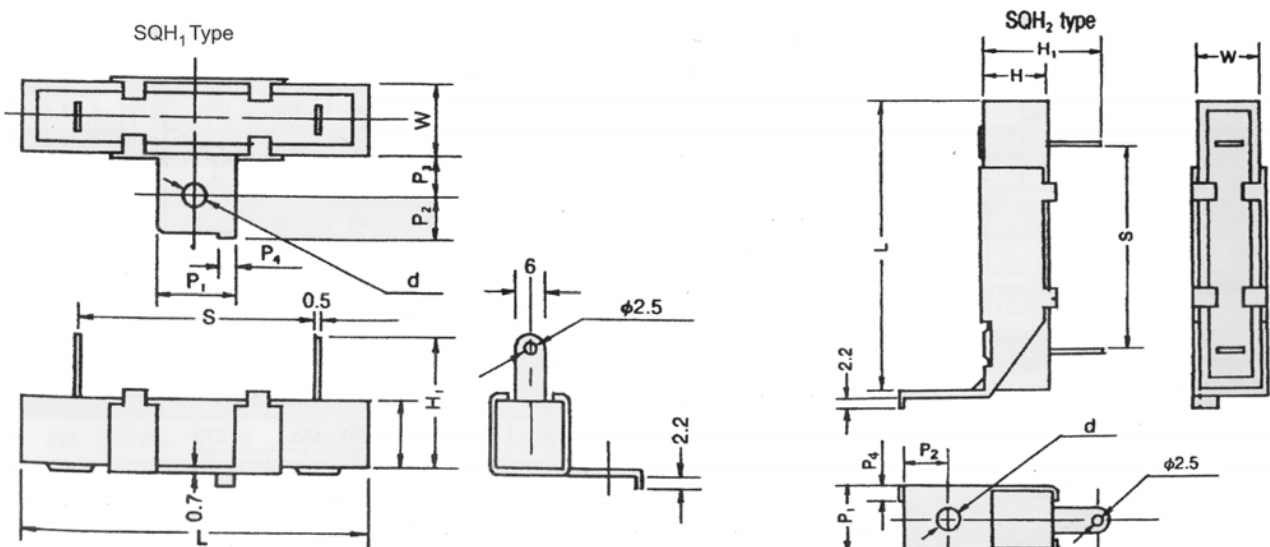

Type	Range of Resistance (Ω)		Dimensions (mm)									
	INSIDE CORE WIRE WOUND	INSIDE CORE METAL OXIDE	L	H	W	S	H1	P1	P2	P3	P4	d
10W	0.1 — 800	801 - 50K	48.0	10.5	10.5	33	19.5	11	6	5.8	2.5	3.8
15W	0.1 — 800	801 - 150K	48.0	12.5	12.0	33	20.5	11	6	6.5	3.0	3.8
20W	0.1 — 1K	1K1 - 150K	48.0	12.5	12.0	48	20.5	11	6	6.5	3.0	3.8
30W	0.5 — 1K	— — —	63.5	19.0	18.0	56	28.0	18	8	10.0	3.0	4.2
40W	1.0 — 1.5K	— — —	90.0	19.0	18.0	71	28.0	18	8	10.0	3.0	4.2

Series SQT NST

SQT (STANDARD TYPE)

NST (NON-INDUCTIVE TYPE)

FROM 5W TO 10W

FEATURES

- Exceptionally small and sturdy ; mechanically
- The materials used and the construction techniques ensure excellent flame resistance, are resistance and moisture resistance as well withstand the most rigorous loading test.
- Tolerances of 5% and 10% are standard.
- Applicable specifications : EIA RS-344 and EIA RC-649

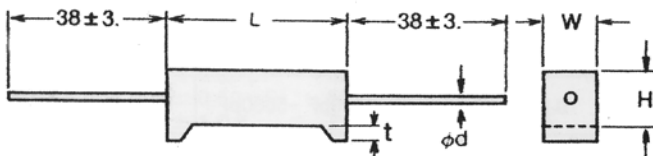

TYPE	DIMENSIONS (mm)				RANGE (OHM)	
	L±0.5	W±0.5	H±0.5	t±0.5	INSIDE CORE WIRE WOUND	INSIDE CORE METAL OXIDE
5W	22.0	10.0	9.0	1.5	0.1-180	181-50
7W	35.0	10.0	9.0	3.0	0.1-430	431-50
10W	48.0	10.0	9.0	3.0	0.1-470	471-50

DERATING CURVE

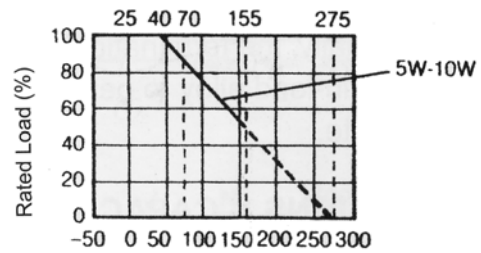

TEMPERATURES RISE

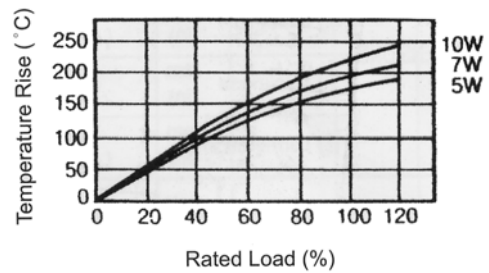

PERFORMANCE

Temperature Coefficient	±300 PPM/°C
Insulation Resistance	>100 MΩ
Load Life (1.000 hours)	±5% +0.05 Ω
Short-time Overload	±2% +0.05 Ω
Dielectric Withstanding Volt	±2% +0.05 Ω
Moisture Resistance	±5% +0.05 Ω
Shock and Vibration	±1% +0.05 Ω
Effect of Soldering	±2% +0.05 Ω